

WITH STAND

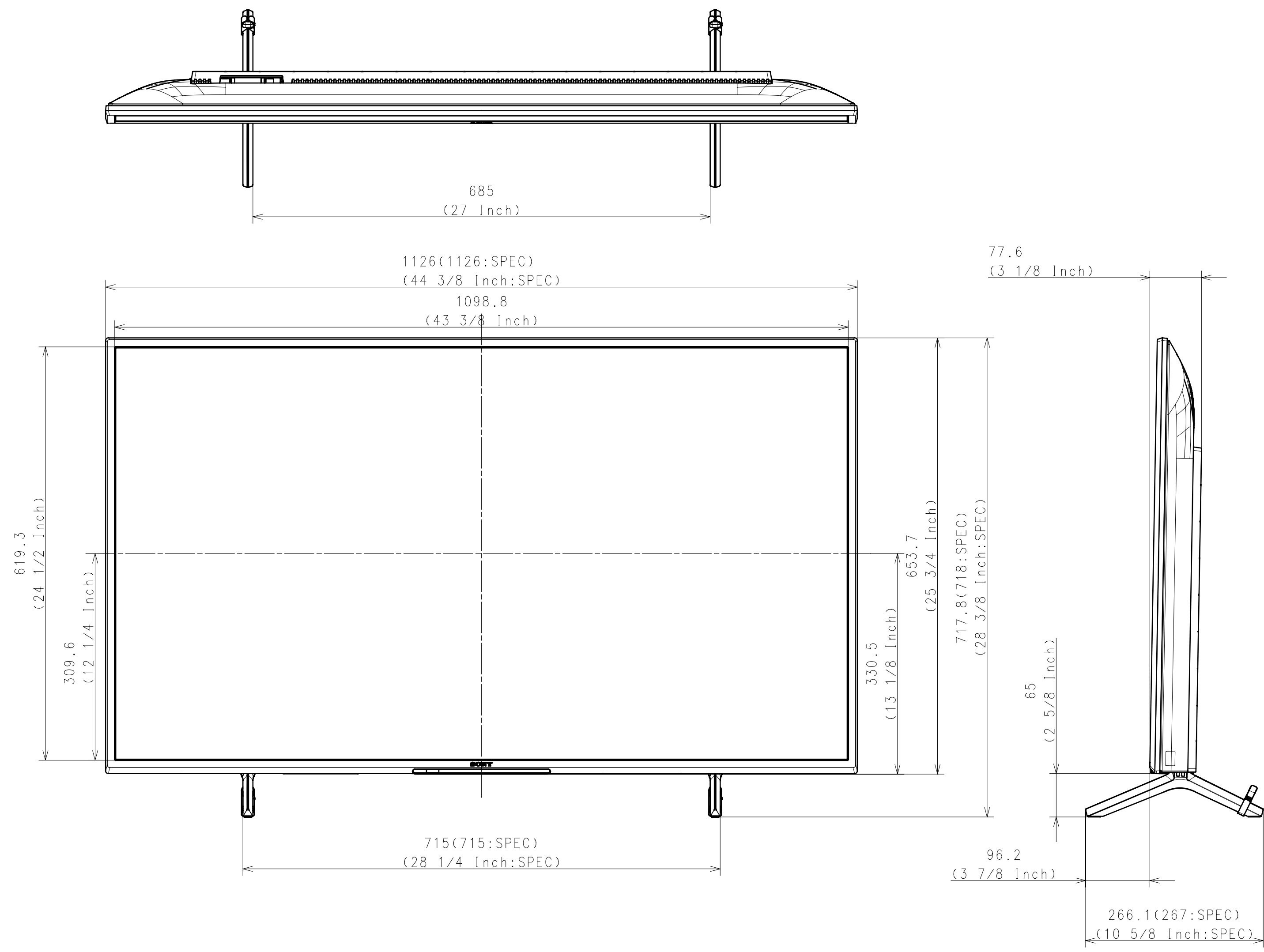

Area		NORTH AMERICA	LATIN AMERICA	GENERAL AREA	
Model Name		KD-50X77L	KD-50X77L	KD-50X77L	
SV No.		SV-41381	SV-41395	SV-41437	
DIMENSION	TV only (W x H x D)	1126 x 653 x 70 mm / 44 3/8 x 25 3/4 x 2 7/8 inch	1126 x 653 x 70 mm	Approx. 1126 x 653 x 70 mm	
	TV only with camera (W x H x D)	-	-	-	
	TV with Stand (Standard position) (W x H x D)	1126 x 718 x 267 mm / 44 3/8 x 28 3/8 x 10 5/8 inch	1126 x 718 x 267 mm	Approx. 1126 x 718 x 267 mm	
	TV with Stand (Narrow position) (W x H x D)	-	-	-	
	TV with Stand (Soundbar position) (W x H x D)	-	-	-	
	TV with Stand (Front position style) (W x H x D)	-	-	-	
	TV with Stand (Back position style) (W x H x D)	-	-	-	
	TV with Floor Stand (W x H x D)	-	-	-	
	Stand Width (Standard position)	715 mm / 28 1/4 inch	715 mm	Approx. 715 mm	
	Stand Width (Narrow position)	-	-	-	
	Stand Width (Soundbar position)	-	-	-	
WEIGHT	TV Only	12.1 kg / 26.7 lb	12.1 kg	Approx. 12.1 kg	
	TV with Stand (Standard position)	12.3 kg / 27.1 lb	12.3 kg	Approx. 12.3 kg	
	TV with Stand (Narrow position)	-	-	-	
	TV with Stand (Soundbar position)	-	-	-	
	TV with Stand (Front/Back position style)	-	-	-	
	TV with Floor Stand	-	-	-	
	Floor Stand weight (Supply)	-	-	-	
	W-M't Br. Weight (Supply)	-	-	-	
	Remarks				

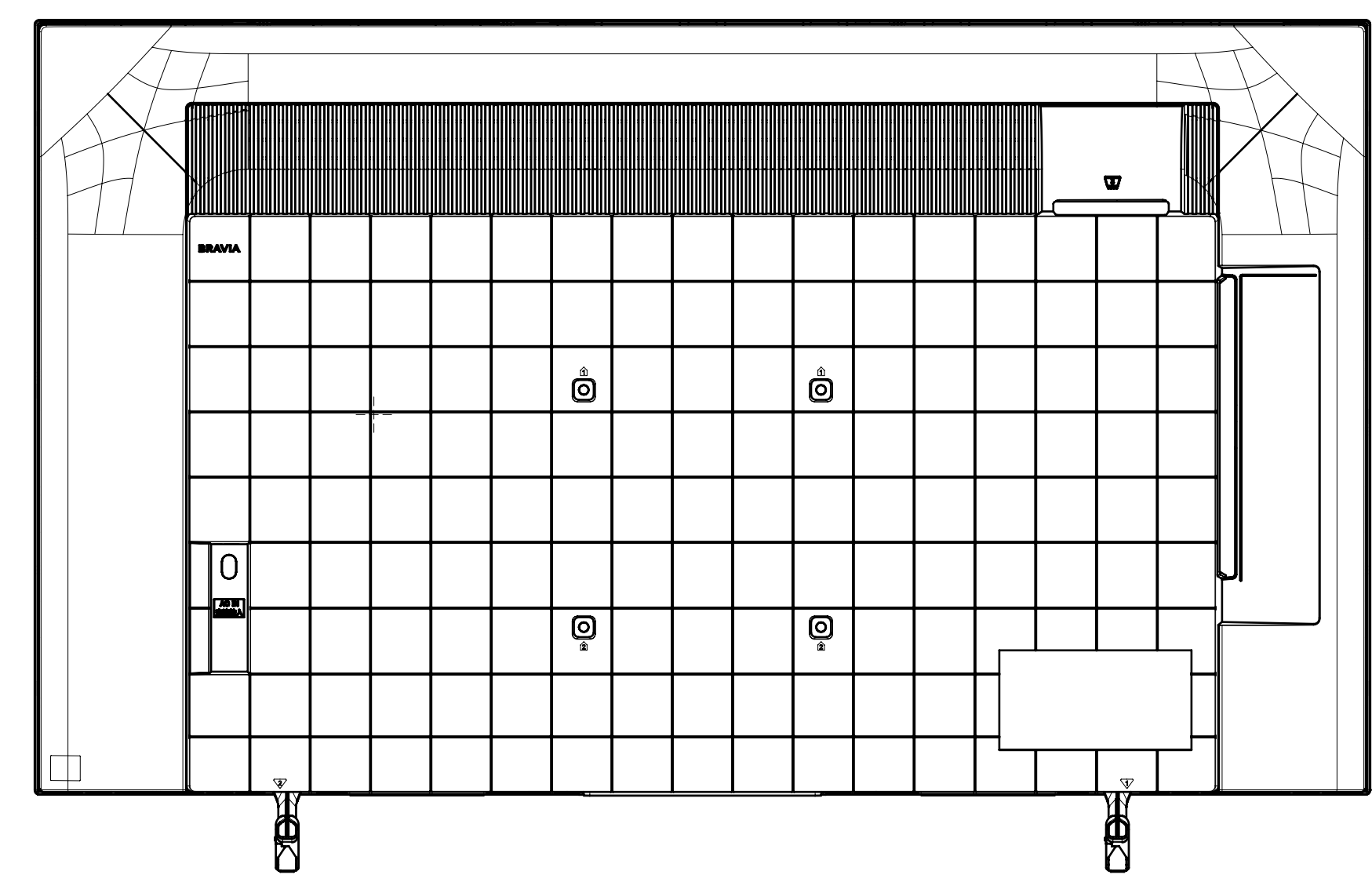

Purchase recycled resins and wire rods only from the business partners that Sony approves as Green Partners.  
再生樹脂・銅線はグリーンパートナー認定者からの調達を促す。

<table border="1"> <tr> <td>△A</td> <td></td> <td></td> <td></td> <td></td> <td></td> </tr> <tr> <td>△B</td> <td></td> <td></td> <td></td> <td></td> <td></td> </tr> <tr> <td>△C</td> <td></td> <td></td> <td></td> <td></td> <td></td> </tr> </table>	△A						△B						△C						<table border="1"> <tr> <td>DATE OF ISSUE</td> <td>2022.12.29</td> </tr> <tr> <td>DOCUMENT TYPE</td> <td>ASSEMBLY</td> </tr> <tr> <td>TOLERANCING</td> <td>DRAWING</td> </tr> <tr> <td>(JIS &amp; ISO/IEC 15010)</td> <td></td> </tr> </table>	DATE OF ISSUE	2022.12.29	DOCUMENT TYPE	ASSEMBLY	TOLERANCING	DRAWING	(JIS & ISO/IEC 15010)	
△A																											
△B																											
△C																											
DATE OF ISSUE	2022.12.29																										
DOCUMENT TYPE	ASSEMBLY																										
TOLERANCING	DRAWING																										
(JIS & ISO/IEC 15010)																											
<table border="1"> <tr> <td>HISTORY</td> <td>SUFFIX</td> <td>RELEASE NO.</td> <td>REVISION</td> <td>SIGN.</td> </tr> <tr> <td>X COUNT</td> <td>PREL. NO.</td> <td>DATE</td> <td></td> <td></td> </tr> </table>	HISTORY	SUFFIX	RELEASE NO.	REVISION	SIGN.	X COUNT	PREL. NO.	DATE			<table border="1"> <tr> <td>MATERIAL COLOR</td> <td>FINISH COLOR</td> </tr> </table>	MATERIAL COLOR	FINISH COLOR														
HISTORY	SUFFIX	RELEASE NO.	REVISION	SIGN.																							
X COUNT	PREL. NO.	DATE																									
MATERIAL COLOR	FINISH COLOR																										
Sony Corporation RESPONSIBLE DEPARTMENT: PANEL & MECHANICAL DESIGN PLANNED BY: _____ CHECKED BY: _____ APPROVED BY: _____ SCALE: 1:5 DRAWN BY: _____ PREP. METHOD: _____ SIZE: A1 UNIT: mm PART NO. _____ SUFFIX: _____ REV. NO.: 1/3		ORIGINAL MODEL: 50(X77L) DESCRIPTION: 50(X77L) EXTERIOR VIEW TENTATIVE MODEL: 50(X77L) EXTERIOR VIEW																									

WITHOUT STAND

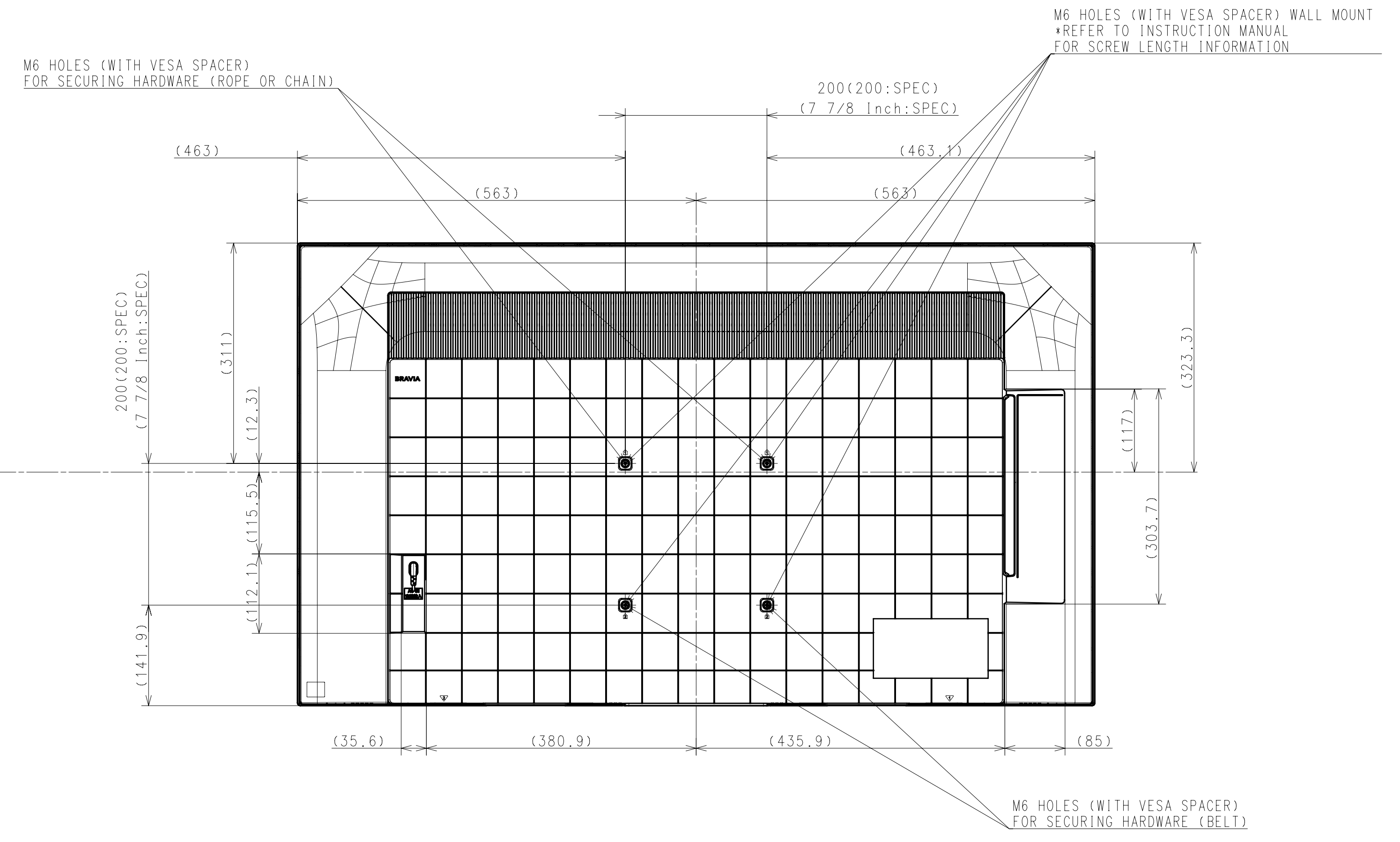
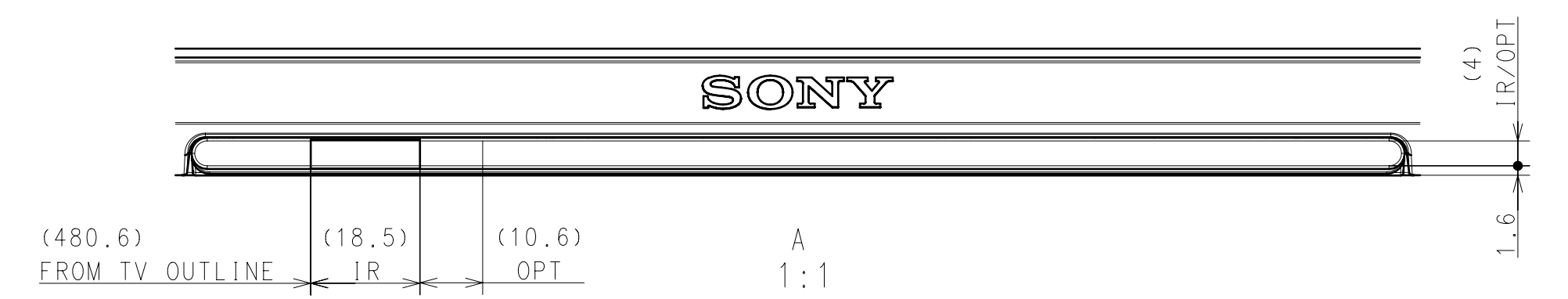
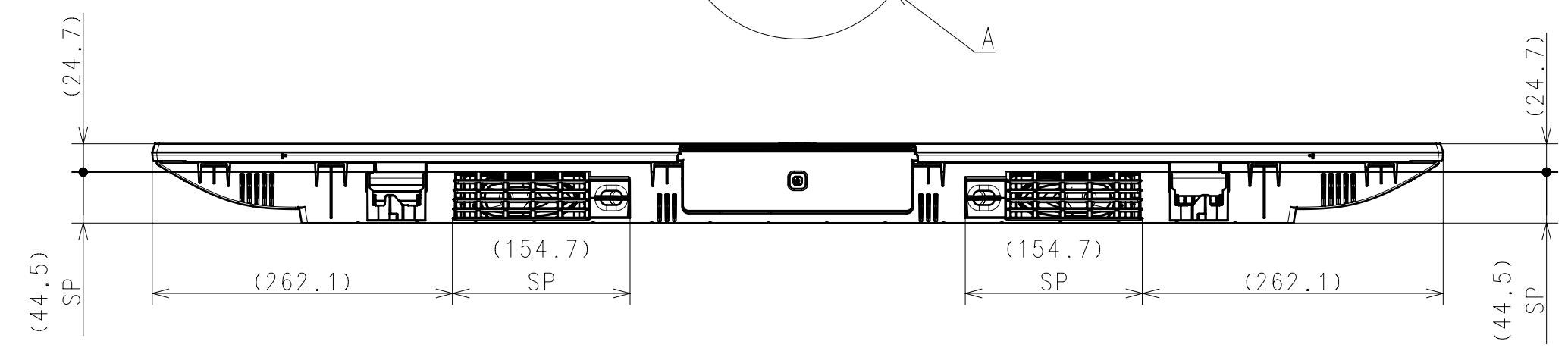
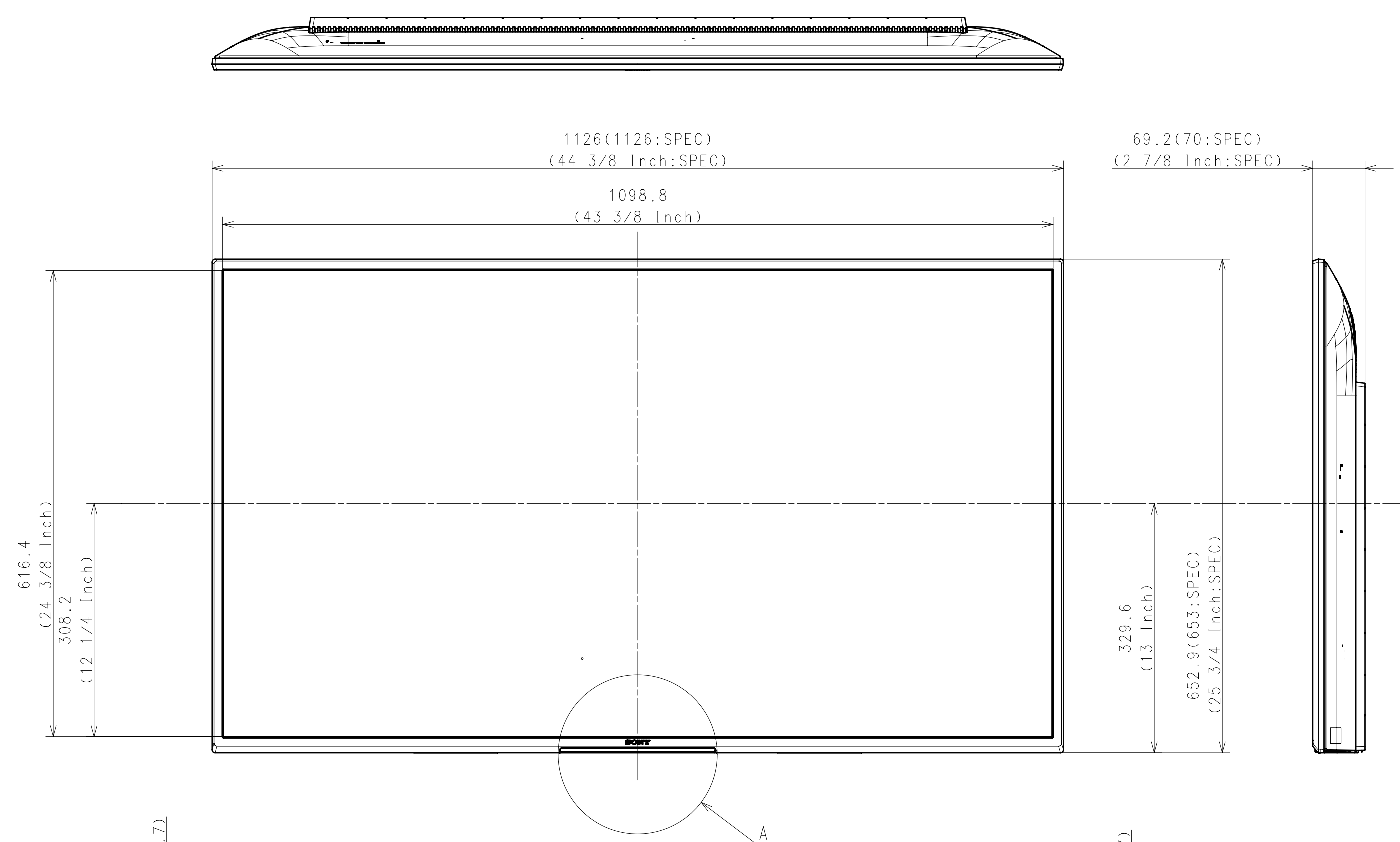

FOR. NORTH AMERICA, LATIN AMERICA, GENERAL AREA

DESCRIPTION 1	LEGAL OWNER	SCALE
50(X77L) EXTERIOR VIEW	Sony Corporation	1:1
DESCRIPTION 2	PART NO.	SHEET/PAGES
50(X77L) EXTERIOR VIEW		2 / 3

SU-WL450

STANDARD

SLIM

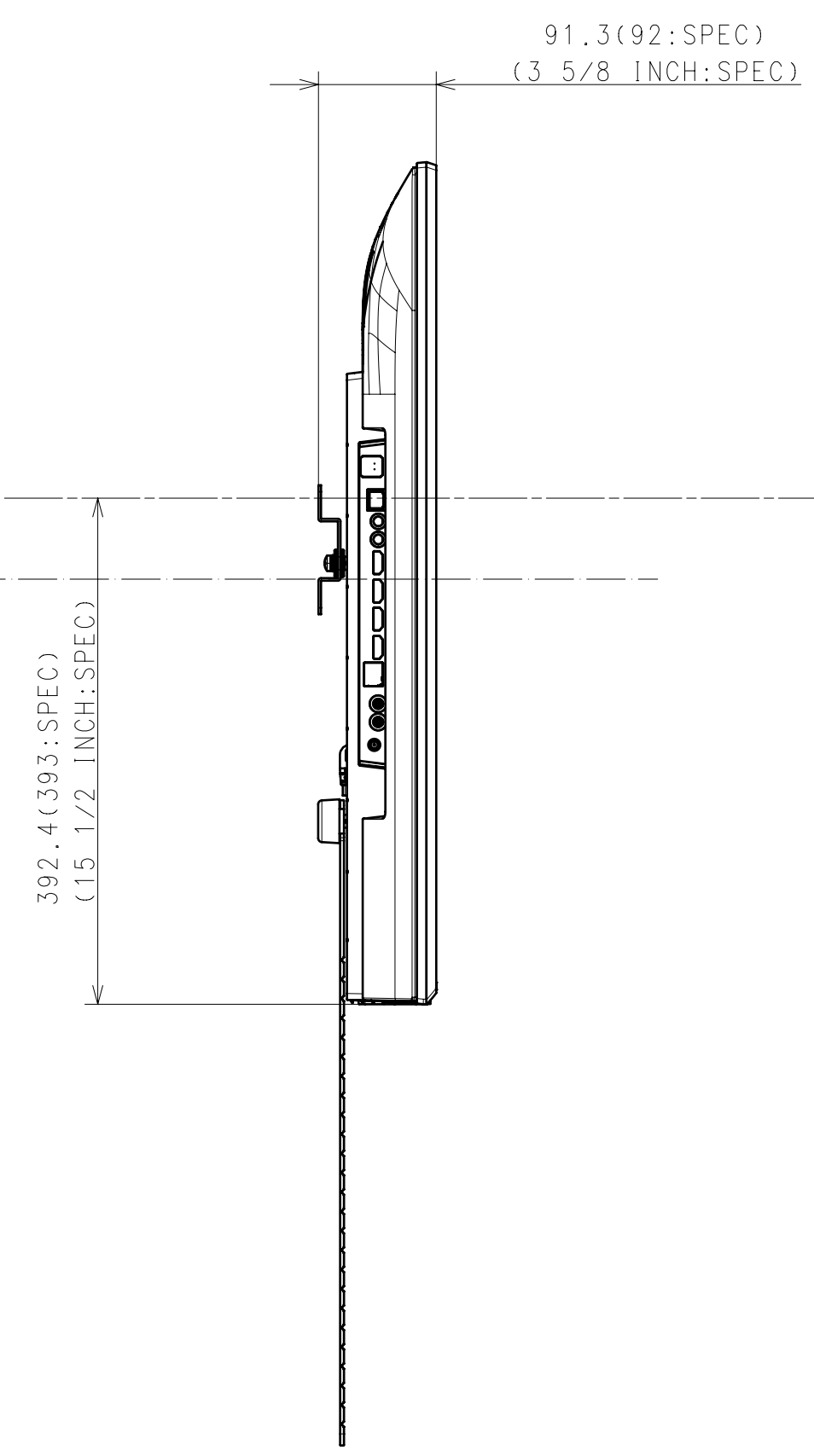
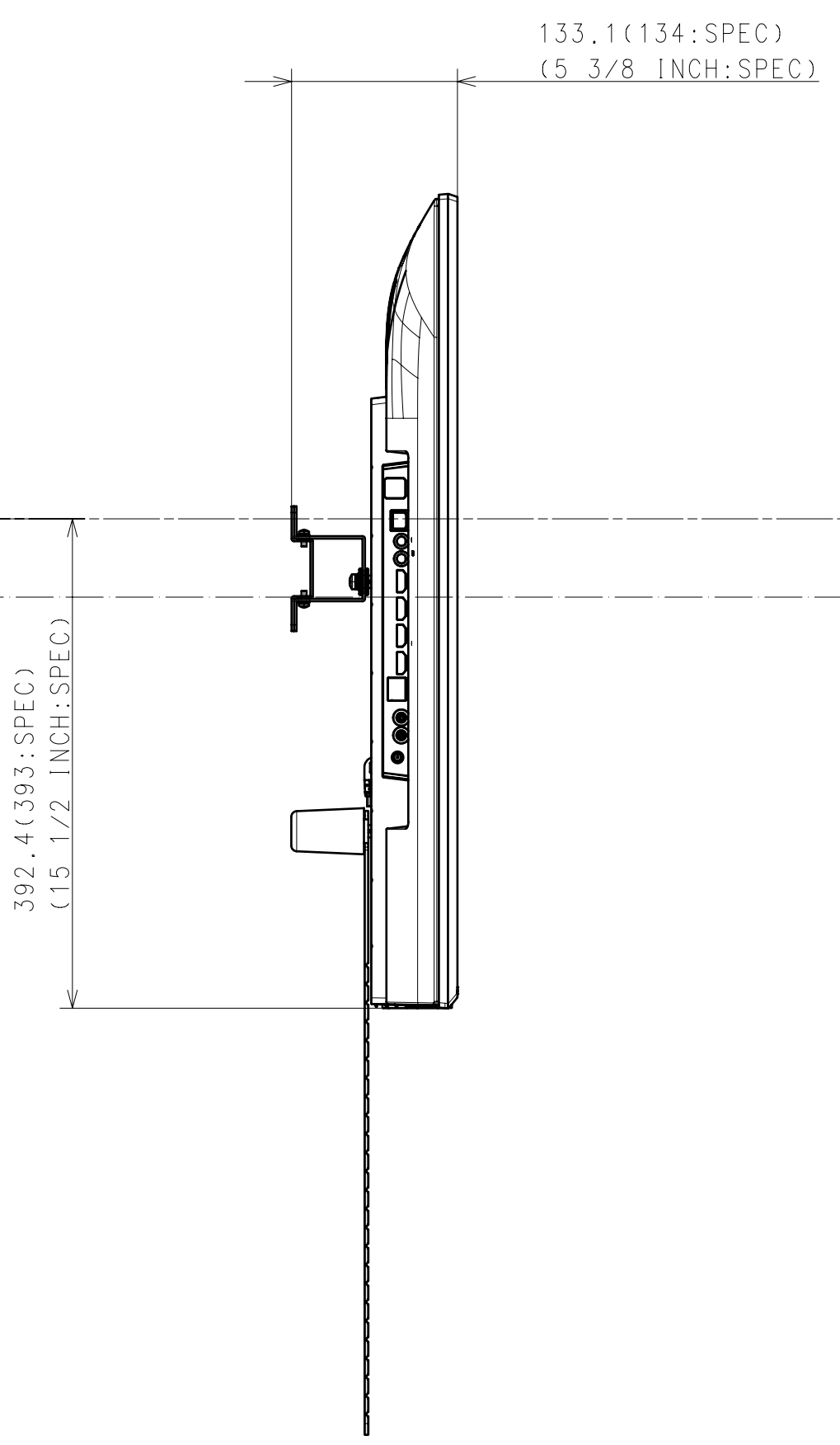
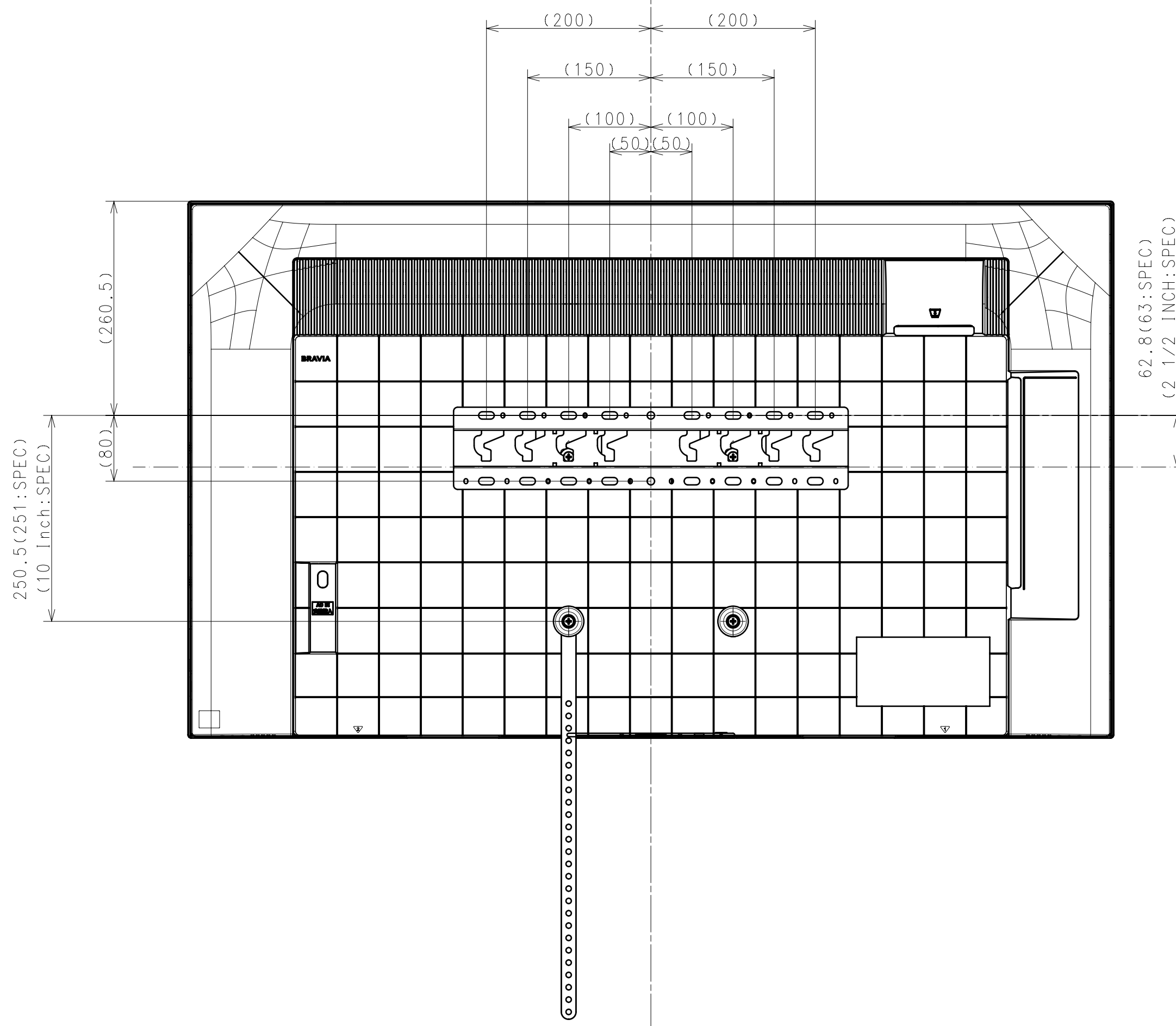

SONY STANDARD

DESCRIPTION1 50(X77L) EXTERIOR VIEW	LEGAL OWNER Sony Corporation	SCALE 1:1
DESCRIPTION2 50(X77L) EXTERIOR VIEW	PART NO.	SHEET/PAGES 3 / 3